

# PDB 80 A

User Manual

V1.0 | 25.03

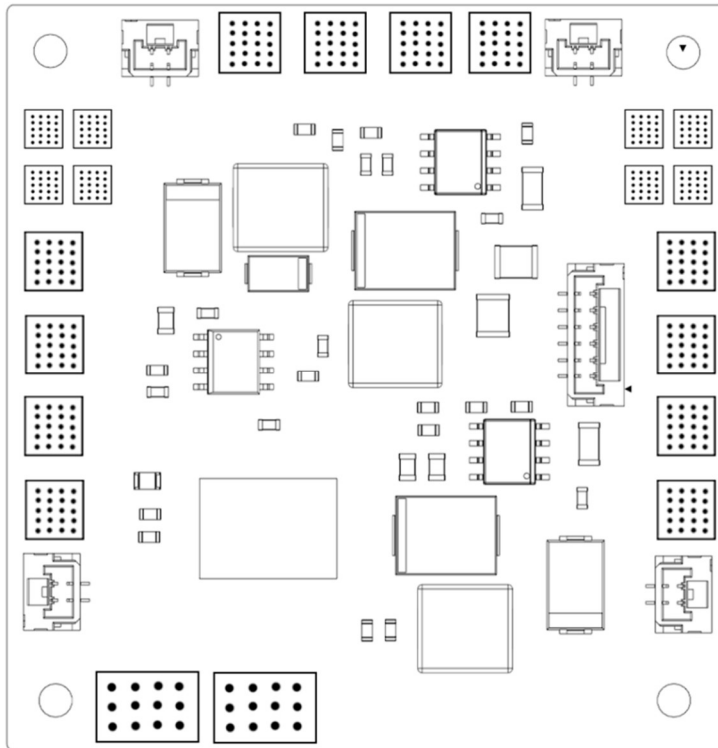



This document is the intellectual property of axldrone India Pvt. Ltd. and is protected under applicable copyright laws. Unless expressly authorized by axldrone, you may not reproduce, distribute, transmit, or sell this document or any portion of its contents in any form.

This document is intended solely for the purpose of guiding users in the proper operation of axldrone products. It must not be used for any other purposes, commercial or otherwise, without prior written consent from axldrone India Pvt. Ltd.

# Table of Contents

Introduction .....	1
Overview .....	1
What's in the Box .....	2
Knowing your PDB 80A.....	2
Technical Specifications.....	3
Installation.....	4
Operation & Telemetry .....	4
Caution & Warnings .....	5
Safety Guidelines .....	5
Maintenance.....	5

## Introduction

### Overview

axldrone's PDB 80 A is engineered to reliably route battery power to multiple ESCs and peripherals while providing precise current and voltage monitoring and clean, regulated outputs for onboard electronics. Built for durability and tight builds, the PDB 150 combines robust power handling with useful telemetry and regulation features to simplify your power architecture.

The PDB accepts a single battery input up to 30 V (6S) and distributes power to up to six ESCs via dedicated +/- pads. It includes integrated DC-DC converters (5 V @ 4 A, 12 V @ 4 A and 3.3 V @ 1.5 A), a Hall-effect current sensor for accurate current telemetry, and a JST 6-pin power connector that carries the 5 V outputs plus CURRENT and VOLTAGE sense lines. The board is manufactured on high-density FR4 PCB material and is 100% made in India.

Key intended uses: multicopter drones, rovers, electric cycle, electric skateboard, etc.

## What's in the Box

1 × PDB 150

1 x 220  $\mu$ F, 50 V Capacitor

## Knowing your PDB 80A

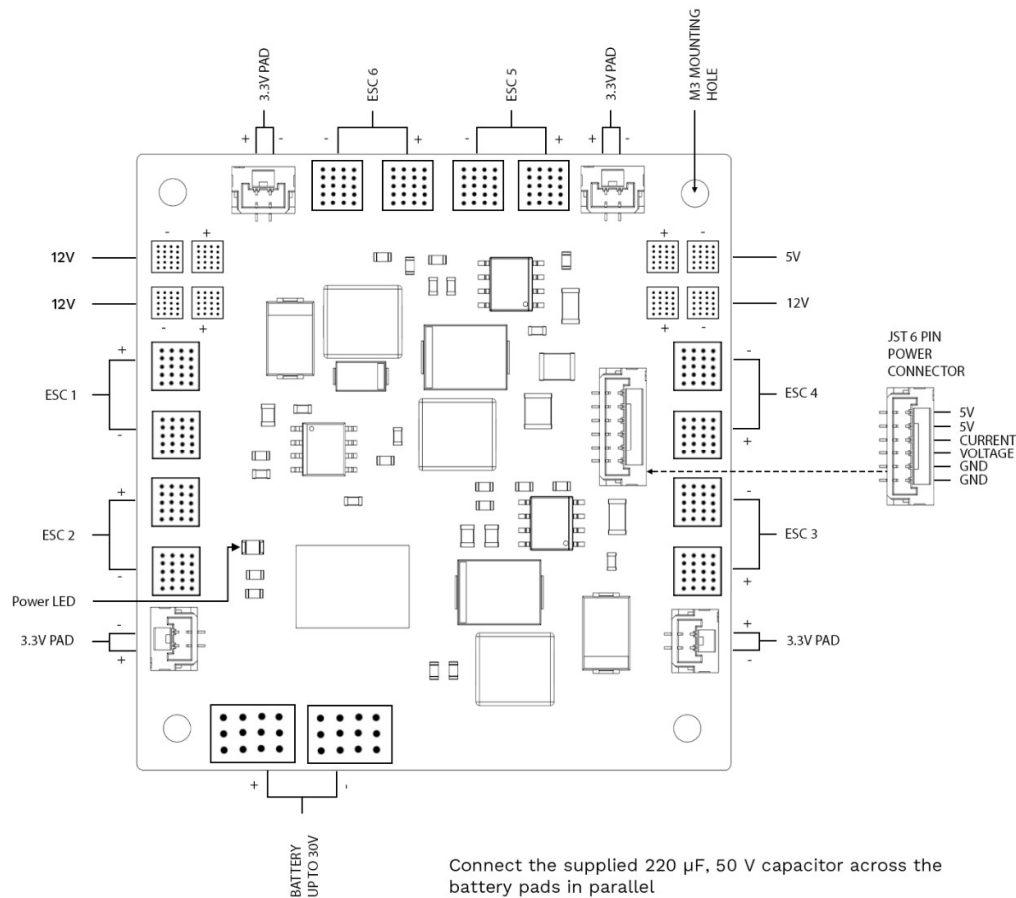

- **Battery Input Pads:** Main battery input pads — positive (+) and negative (-). Accepts up to 30 V (6S LiPo).
- **ESC Pads:** Six ESC output pads, each with + and - power pads (labelled ESC1 → ESC6 on board).
- **Regulated Outputs / Peripheral Pads:** Dedicated pads for 5 V, 12 V and 3.3 V outputs.
- **JST 6-pin Power Connector:** Single 6-pin JST connector that supplies regulated 5 V outputs and carries the voltage/current sense signals plus ground.

- Mounting: Four mounting holes for M3 screws.
- Use M3 hardware and non-conductive standoffs if mounting to a conductive frame.

## Technical Specifications

Feature	Specification
Model	PDB 80A
Mechanical Size	54 mm × 56 mm × 7.5 mm
Mounting Hole	M3 (four mounting holes)
Weight	18 g
PCB Material	High-density FR4
Input Voltage Range	Up to <b>30 V</b> (supports up to 6S LiPo)
Maximum Current Handling	Up to <b>80 A</b>
Number of Output Channels	Supports up to <b>6 ESCs</b> (six +/- power pads)
Integrated Voltage Regulators (DC-DC / BECs)	<b>5 V / 4 A, 12 V / 4 A, 3.3 V / 1.5 A</b>
Power Connector	JST 6-pin power connector (5V, 5V, CURRENT, VOLTAGE, GND, GND)
Sensors	Integrated Hall-effect current sensor and voltage sensing for monitoring/telemetry
Country of Manufacture	100% Made in India

Recommended Use	Multirotor UAVs — power distribution for ESCs and peripherals
-----------------	---

## Installation

- Connect battery + to the board' battery + pad and battery - to the board' battery - pad. (Connect - first, then +.)
- Connect the supplied 220  $\mu$ F, 50 V capacitor across the battery pads in parallel — ensure positive to positive and negative to negative.
- Each ESC power lead (+ / -)  $\rightarrow$  corresponding ESCx + / ESCx - pads. (ESC signal wires go to your flight controller separately.)
- Use the regulated 5V, 12V outputs to power your flight controller, sensors, cameras, and other onboard peripherals.
- Use the 3.3 V connector to power sensors and cameras requiring 3.3 V.
- Ensure all grounds (battery -, ESC -, JST GNDs, FC ground) are common and securely connected.

## Operation & Telemetry

**Voltage Telemetry:** The board provides a scaled voltage output on the telemetry pin for flight controllers capable of reading external battery voltage.

**Current Telemetry:** The Hall effect sensor provides a current signal that the flight controller or telemetry module interprets.

## Caution & Warnings

- Do not exceed 30 V. Exceeding the input voltage will damage the board.
- Observe polarity carefully. Reversing polarity will likely destroy the PDB and connected devices.
- Do not expose the board to water, moisture or conductive debris.
- If the PDB runs hot under high load, provide ventilation or relocate heat-sensitive components.
- **The supplied 220  $\mu$ F/50 V capacitor must be installed across the battery pads. Damage to the board resulting from failure to use this capacitor will invalidate any refund or warranty claims.**

## Safety Guidelines

- Disconnect battery before any wiring, inspection or maintenance.
- Inspect solder joints and connectors before each flight.
- Securely fasten ESC and motor wires; loose wires can cause a short.
- Use proper fuses or ESC-level protection where necessary to protect wiring and motors.
- Do not attempt repairs beyond basic connector/solder work — consult qualified technicians for PCB level repairs.
- Keep away from children and untrained personnel when the battery is connected.

## Maintenance

- Periodically inspect the board for loose solder joints, cracked traces or damaged pads.
- Clean dust/debris with compressed air; avoid solvents that damage silkscreen or components.
- If corrosion or discoloration is present, discontinue use and replace the PDB.  
Handle electronic waste responsibly. Dispose of the board in accordance with local electronic recycling regulations.

Visit Our website



Feel free to connect



Digital Hub, Kerala  
Technology Innovation  
Zone, Kinfra Hi-Tech  
Park, Kalamassery,  
Kochi, Kerala 683503  
Ph: +91 949 771 7654  
E : info@axldrone.com

C5 UL Cyber Park,  
Special Economic Zone  
Calicut, India – 673016  
P : +91 9645 426 414  
E : info@axldrone.com



1441 Broadway,  
#5, New York, NY 10018  
P : +(646) 260-6311  
E : info@axldrone.com